

A: in order to make an OU device you need an idea for example, "compensate self-induction" we take two opposite coils, current is high, the inductance is small, but there is a magnetic field under the windings

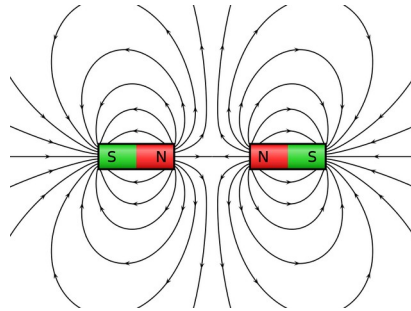

now if we put a pickup winding there will be nothing in it because everything is symmetrical

A: this way ?

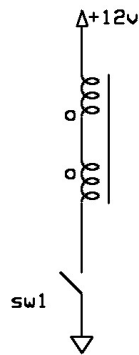

B: yes

geometry of windings is very important here

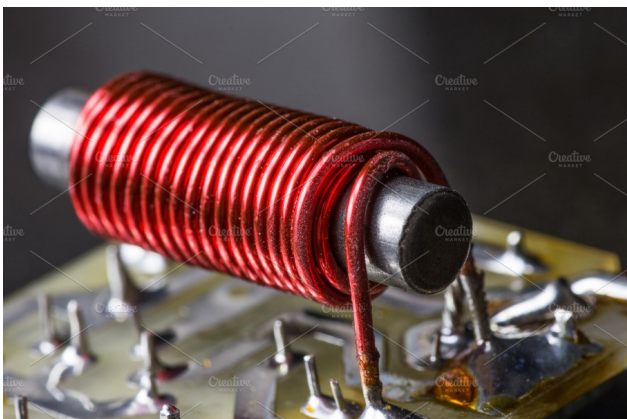

This will not work



This will work



This not

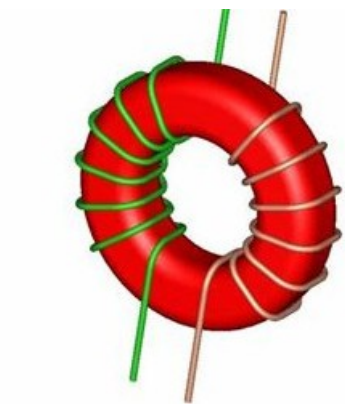

This will

A:

so it is necessary to introduce asymmetry during demagnetization
have you drawn the diagram of what I described?
is it possible to have a separate winding with a diode like flyback

A:

we magnetized the core at "low cost"
now we want to take it away, we put in pickup winding and a diode
so it will not interfere with magnetization
here is one secondary on top of one of the primary halves

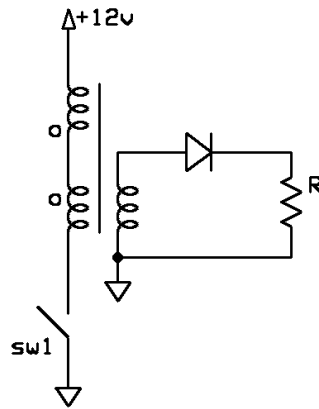

A: do you see what is still missing ?

B: we need reverse one of the fields

A: this would be cool :)

it is just enough to make demagnetization of the halves asymmetric

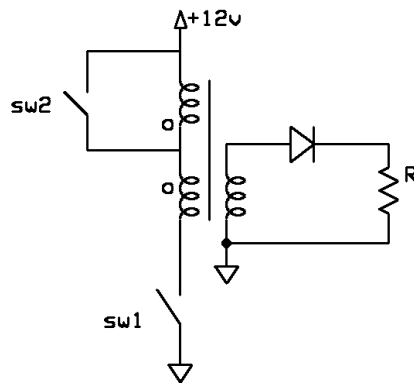

shorting one of the primaries delays demagnetization of the core under it

B: Well then you can put a load there right away

And why do you need another switch, isn't a diode enough?

A: if you put two loads it will be symmetrical again

there is a large voltage drop on the diode

and there is a small detail still missing here

B: where?

A: small choke to limit magnetizing current

B: Then the choke's energy can be put into use

it is possible to use the choke's energy to then reverse the second field, or at least slightly increase the imbalance when extracting energy

A: OK

control question

what errors you see on this schematics from the internet ?

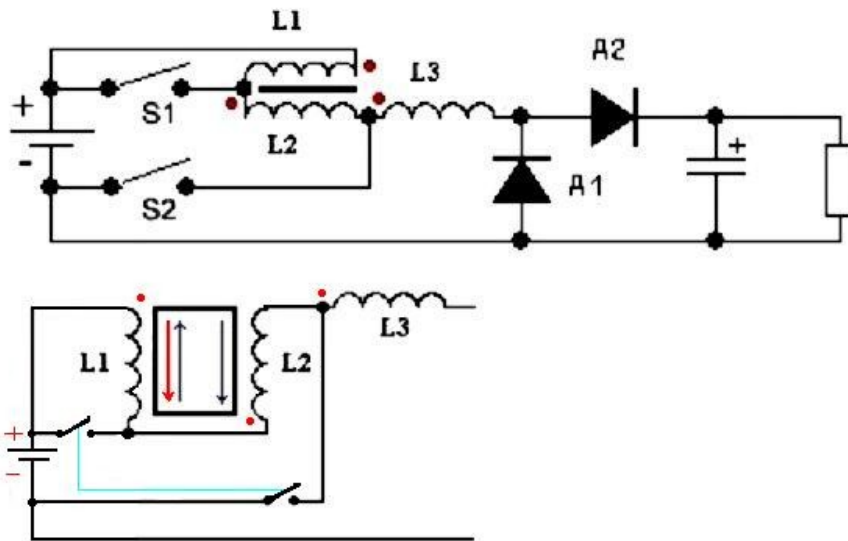

B: I would draw a new one to be honest, the bottom one is not finished at all firstly, one coil needs to be reversed, so that at least two compensate each other switch S2 is not where it should be, it should be placed after L3

A: the switches should work in anti-phase and not together the windings should be on different halves of the core and not on one as shown above

A: just in case, I remind you once again - **the device might be dangerous to your health**, be careful or you will start behaving like <name removed> :)

Here is a functionally equivalent circuit built around a DC-DC converter

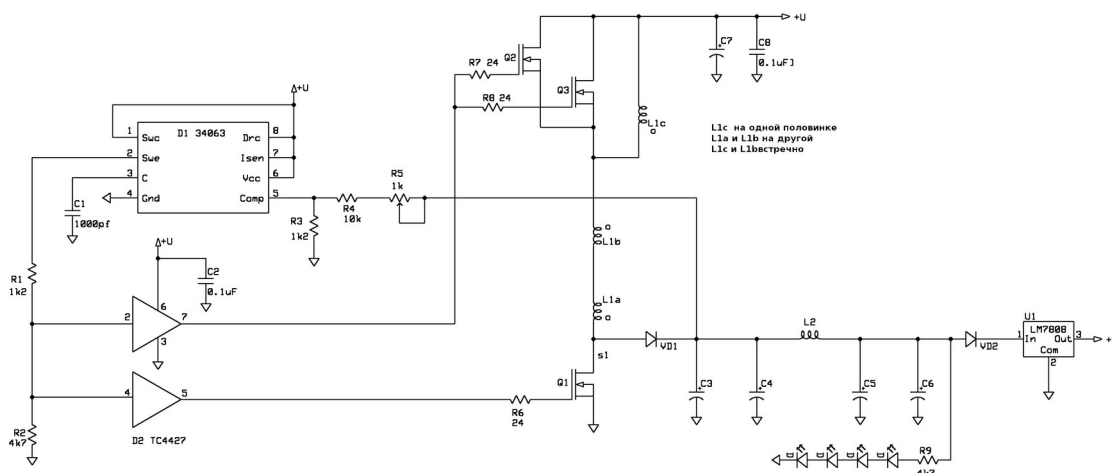

L1c on one core half, L1a and L1b on the other, L1c and L1b in opposite

A: here is the same thing but using alternating current, two-frequency with saturation to create asymmetry

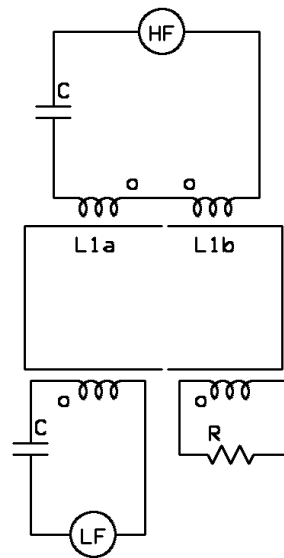

Also I think similar idea could be built around magnetic amplifier making output coils slightly different.

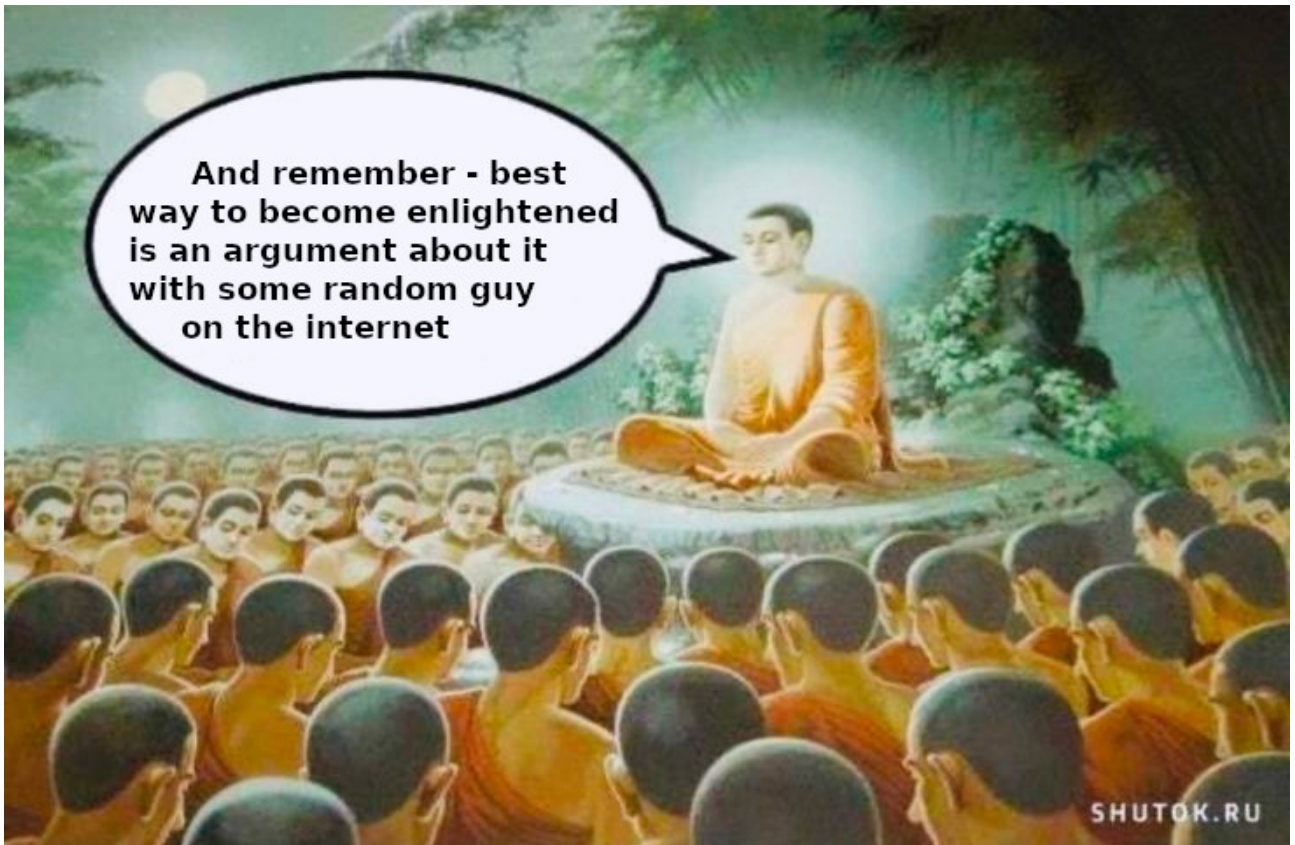

Have fun :)