

Let's start with the fact that it's just a joke to say that the BTG is fuel-less. But in reality, to achieve significant results in this so-called fuel-less system, you still need to use some kind of fuel! Look, for example, the Koreans also used this type of fuel in their BTG; I'm saying this to make it clear and understandable, and also to avoid making unfounded claims:

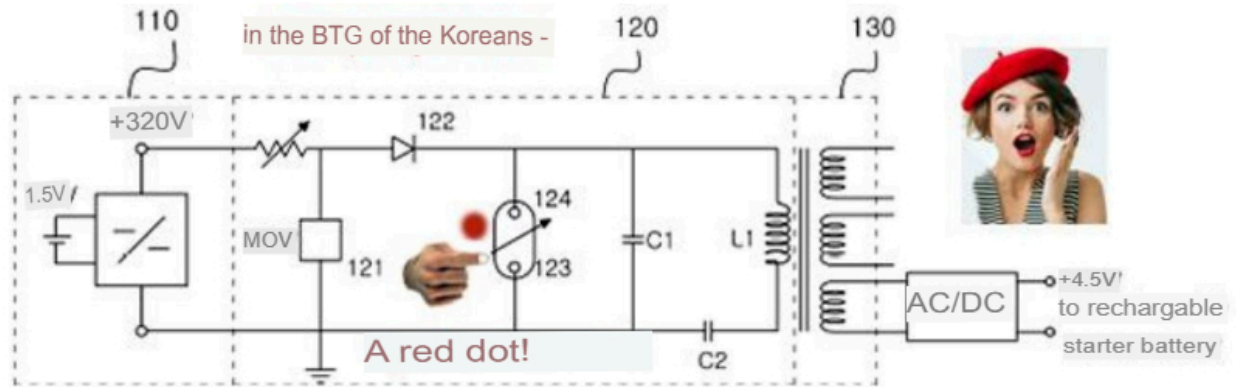

And, without further ado, let's get started

right away : The first thing we need to do is create a source of the energy itself (the fuel itself !) The fuel will be mercury itself, or rather its amalgam; which we must prepare ourselves, with our own hands. This amalgam is not quite ordinary; at first it is liquid like mercury itself, in the second phase it will become like plasticine ; and in the third, it will harden like everything we know - solid. There are 2 methods to create such an amalgam.

1st: You need copper sulfate (50-75 gr.) +

water for dissolution; to obtain finely dispersed copper (in

sediment), you will have to add aqueous sulfate - an antioxidant, in the

form of sorbic acid powder! (vitamin - C), a heaped tablespoon to the solution; and

the appearance of the blue sulfate solution will change to dark green. Next, a precipitate of very fine red copper will settle to the bottom of the container. Carefully drain the solution,

and rinse the copper at the bottom further . Combine this copper with mercury in a small amount of clean water. Add 60 grams and mix with the finely dispersed copper.

Then, remove from the air and, squeezing out the excess in a paper towel (into the container), mix until it reaches a "plasticine" consistency. Quickly apply this amalgam

to the tube, bending it onto the tube; stretch it along the tube to a length of 4-5 centimeters.

Attach a nichrome wire (0.8 mm in diameter, or better yet, 1 mm) to the very edge . Let it set/

harden! 2nd: You need a 20% nitric acid solution in water. This method is simpler, but it's

dangerous because it uses acid, so it won't be described further ! For safety reasons. Here's what it looks like (picture):



40 mm. This indicates the length of the amalgam lining along the pipe itself.

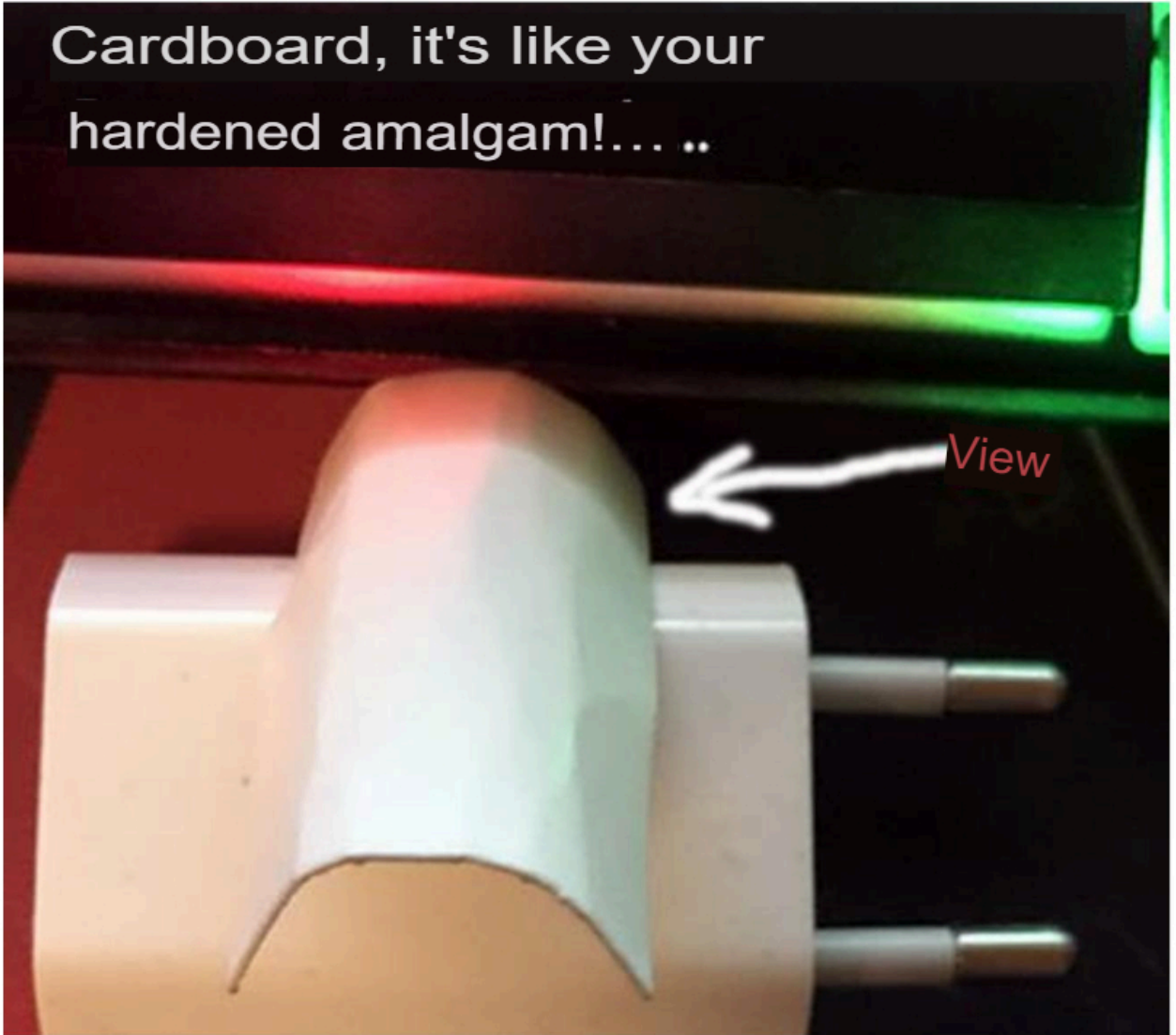

The procedure (below) for amalgam in a hardened consistency:

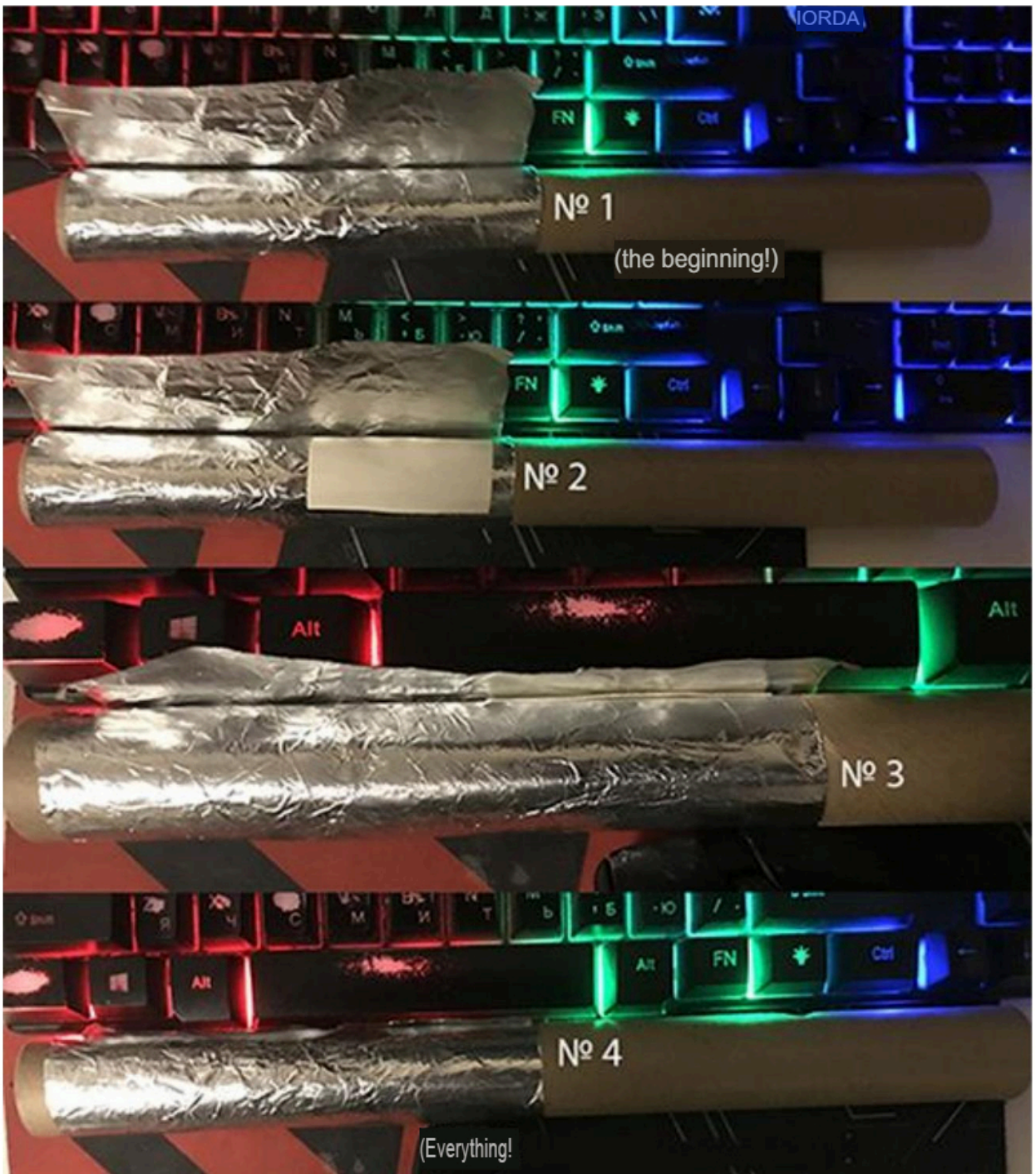

Winding a couple of turns of foil onto the bare tube; then installing the hardened amalgam closer to the edge; then again on top of the amalgam, another 2 turns. Next, at a distance of 2 cm from the active foil, a blank is wound aluminum without anything 4 turns of foil (this is the passive side) but, in it A semicircular nichrome wire, also 0.8-1 mm thick, is inserted into the end of the active side to receive the emitted ions from the ion wind, i.e. from the active side.

The active side (foil with hardened amalgam) is required to be actively Excitation. There are two ways to excite: either with a driver from an old-style energy-saving lamp, i.e. one with mercury vapor inside. You will need either 11 watt or 15 watt ones; the most powerful ones are not necessary,

So that their power doesn't burn out the nichrome inserts in both the active and passive foils. Here's an example for clarity:



- The drivers look like this:

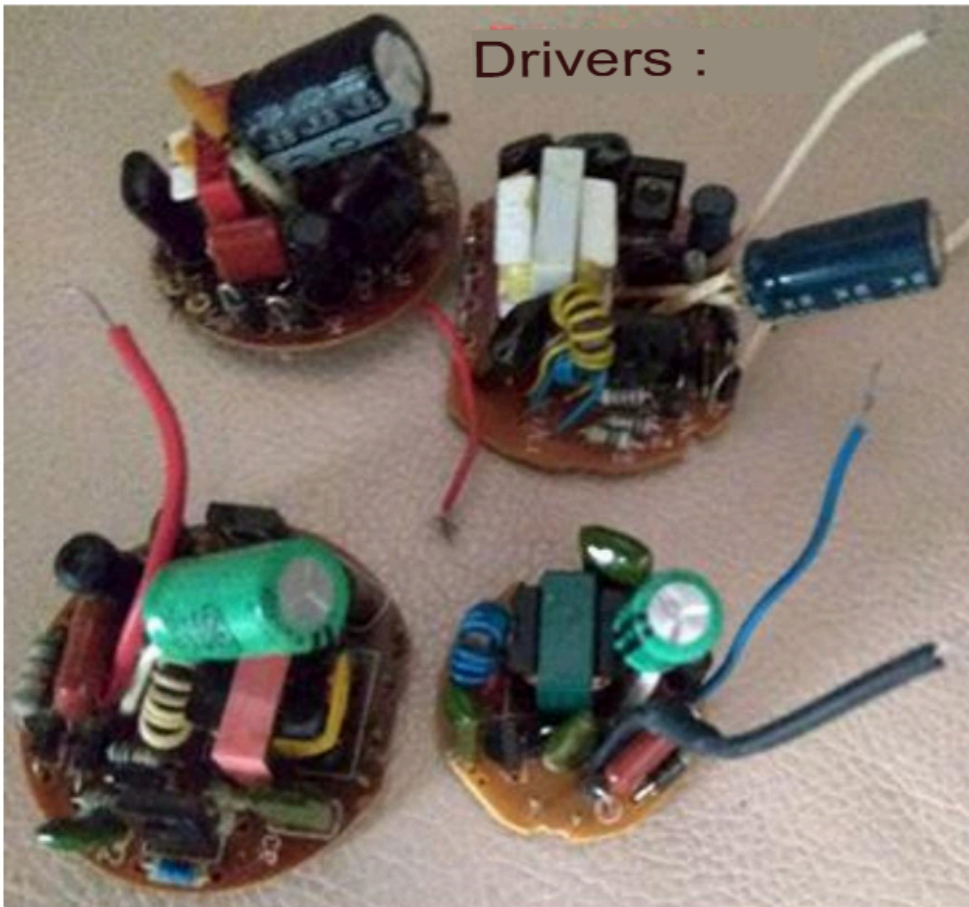

At the output of such a driver, a line transformer of approximately this type is installed - pumping the active foil:

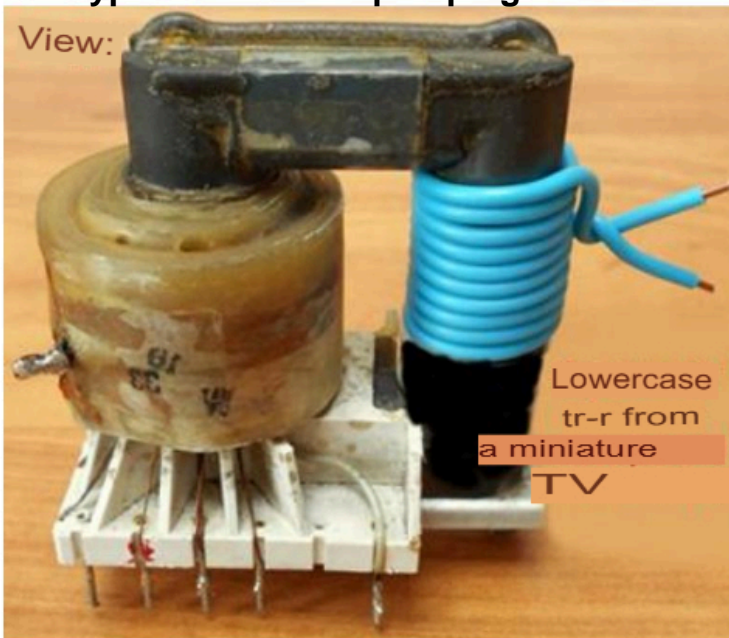

Or, in another case, you can connect this one:



If you don't want to use an energy-saving lamp driver, then you'll have to do everything yourself , and something like this , (as in the book - Bob(a) Yanini):

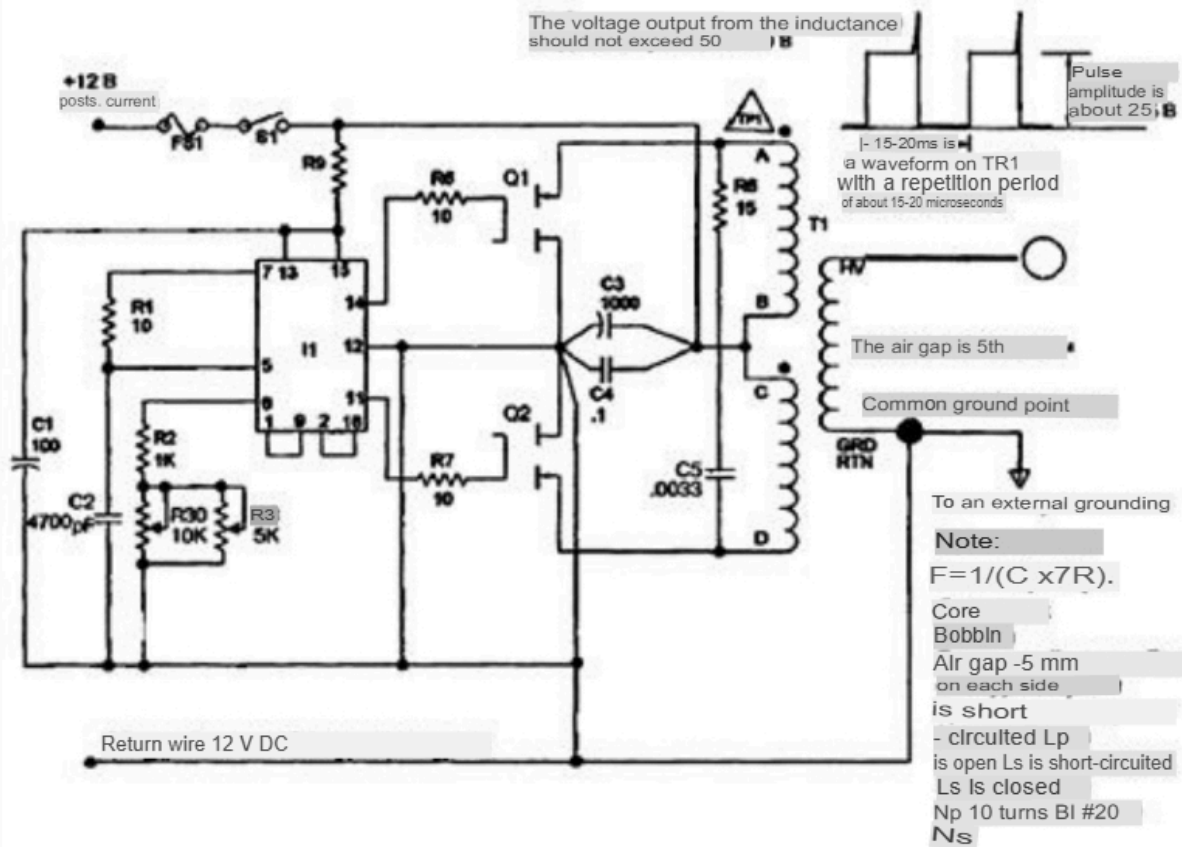

Fig. 17.2. Schematic diagram of the device

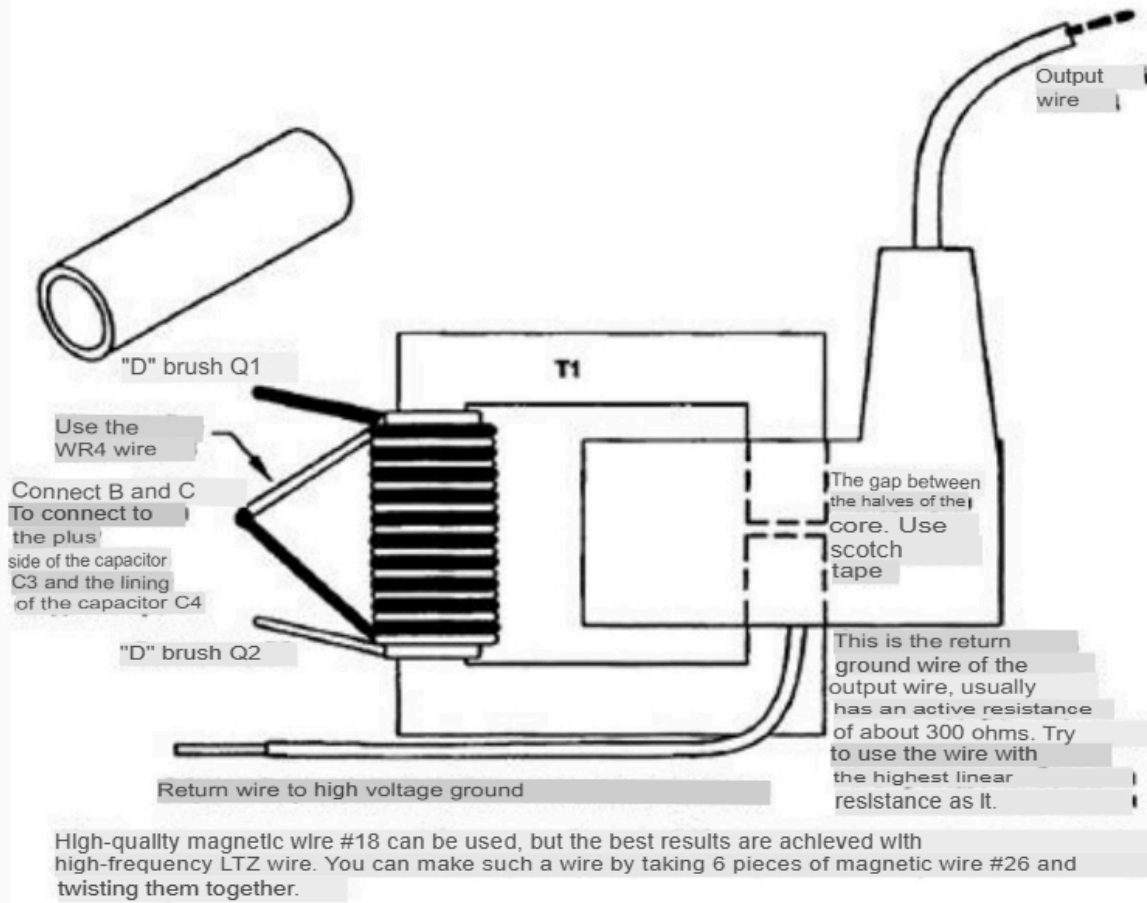
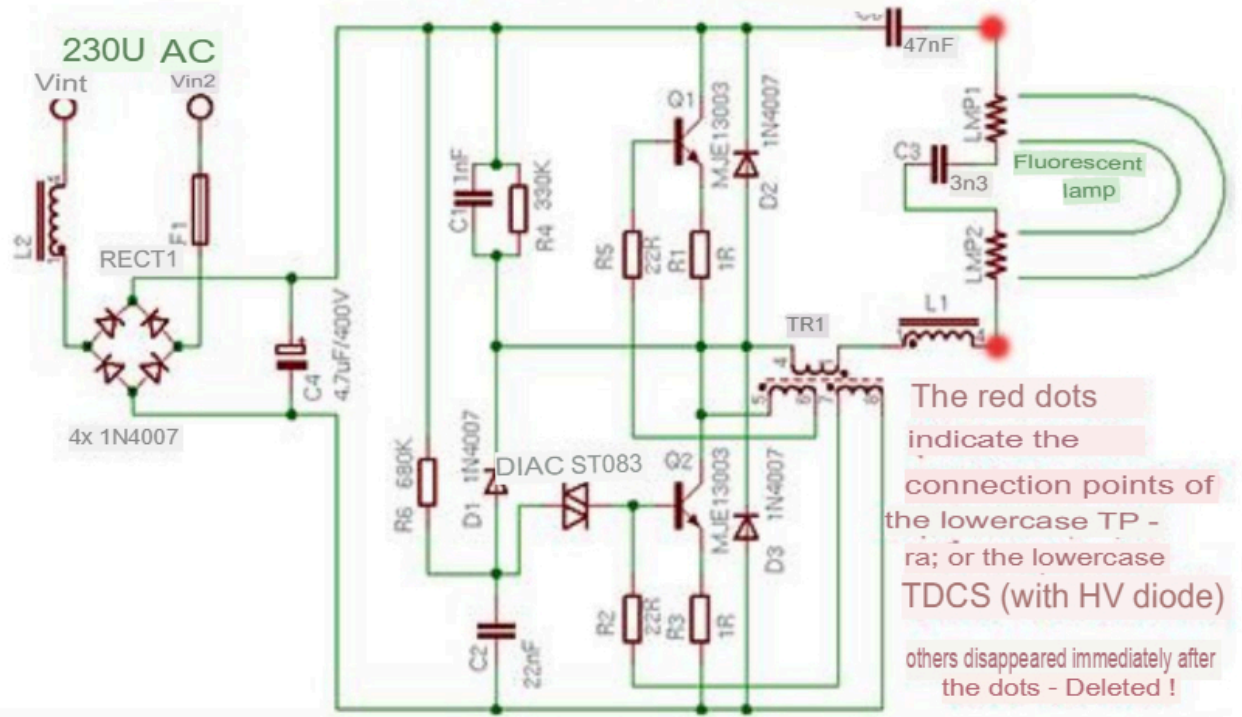

Fig. 17.3. Modification of the line transformer to perform the functions of the Tesla T1 coil

If manufactured with a driver! - energy-saving lamp - the circuit will look like this:

LUXAR - 11 Wart:



Some people might not like to power the power saving driver. 220 volts, since you'll need a homemade inverter for this purpose!... Therefore, below is an alternative option that could serve as a good replacement, with a 9-volt power supply:

ENERGY-SAVING LAMP FROM 12V

I was winding it by eye and by memory, interpreting the size of the cores, according to the continuous winding scheme. First, I wound the collector winding with 10 turns of 0.4mm wire, the second with a base 6 turns of 0.2mm wire, laid an insulation layer, and overlapped the load winding with 0.1 wire, which turned out to be about 330-340 turns. I connected a lamp from a 7w scanner to the load, and the device immediately started working, as evidenced by the light coming from the lamp. There was a 13-watt energy-saving lamp with a burnt-out spiral nearby, I decided to try to overpower this brainchild with a similar load. I was pleasantly surprised, with a current of half an ampere at a voltage of 12 volts, the lamp shines brightly enough.

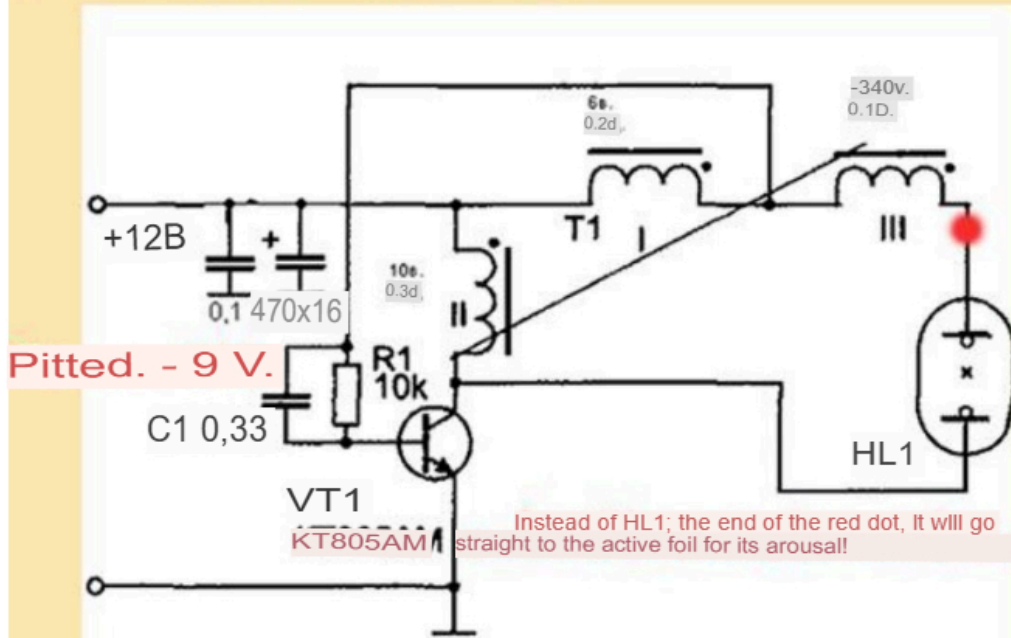

It also runs on two lithium-ion batteries, although it consumes 150 Ma more. I soldered it together with a hinged mounting (4 parts) and that's it

If you want to power a 220-volt lamp driver, you can use a homemade inverter like this (as an example):

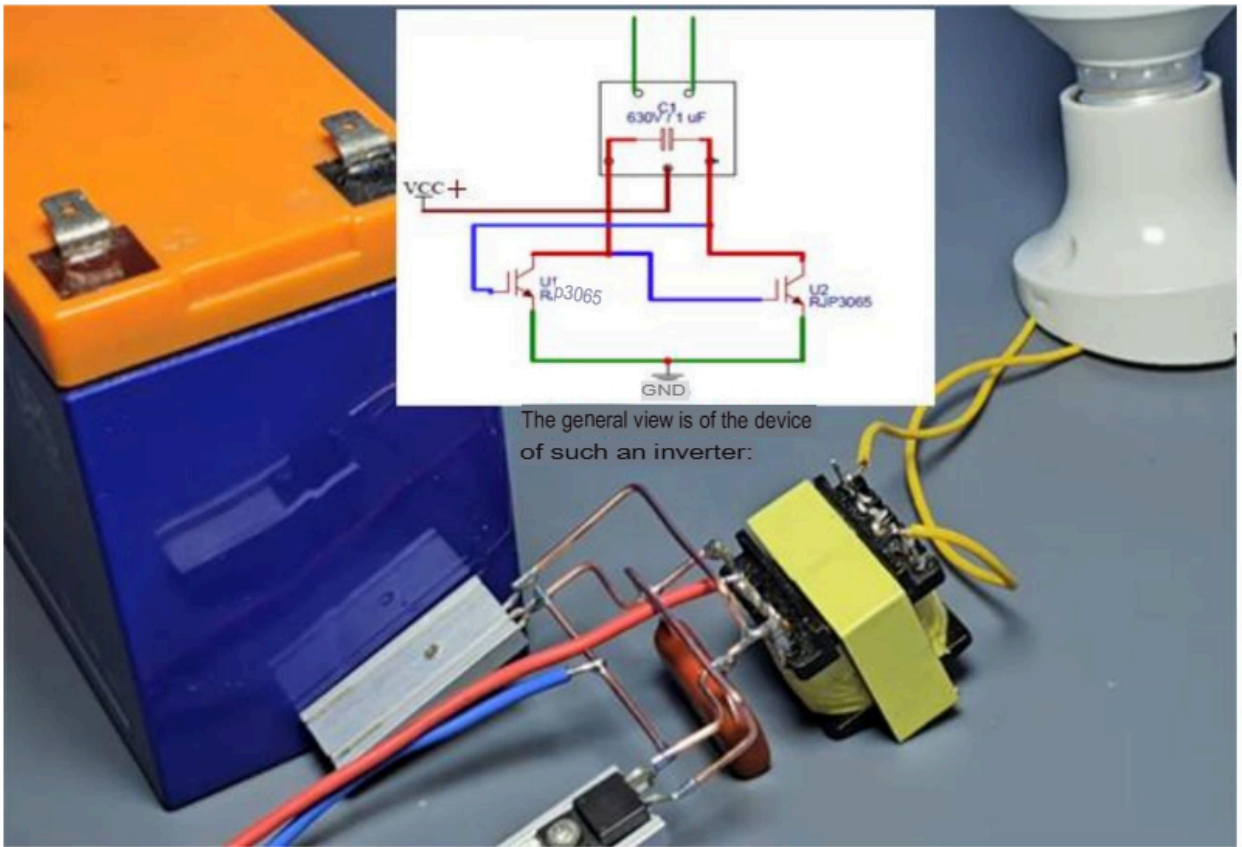

The general view is of the device of such an inverter:

It all depends on personal preference; some people might be satisfied with this option:

Direct current to alternating current conversion circuit from 12 V to 220 V

This homemade DC to AC converter from 12V to 220V is built on CMOS 4047, which is the main component of this small voltage converter that converts 12V to 220V. The 4047 is used as an unstable multivibrator, pins 10 and 11 will have a symmetrical rectangular signal that is amplified by two Darlington transistors and finally reaches secondary winding of the mains transformer ($2 \times 10V/60VA$).

At the terminals of the transformer of the main voltage converter, it will be 220 V.

With P1, the output frequency can be adjusted in the range from 50 Hz to 400 Hz. Although it is not included in any professional DC to AC converters, it can be used quite effectively in some household appliances.

Schematic diagram of a DC-to-AC converter

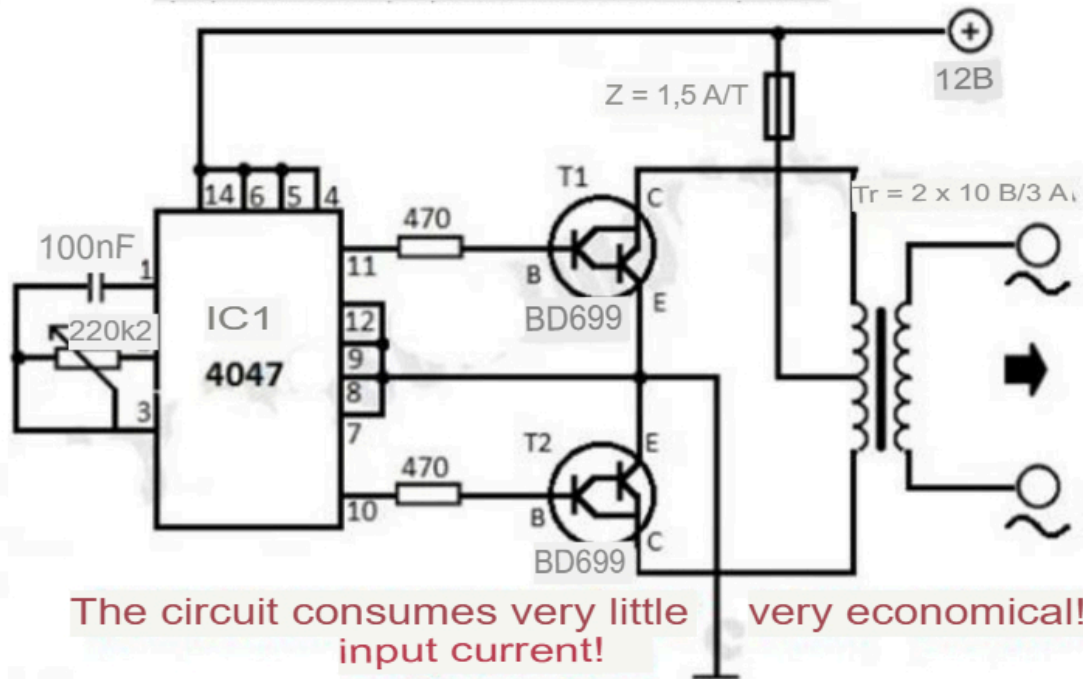

The circuit consumes very little input current! very economical!

Now, the second method of exciting the active foil is radio frequency with 50 Hz modulation in the high-frequency spectrum. The diagram is shown below:

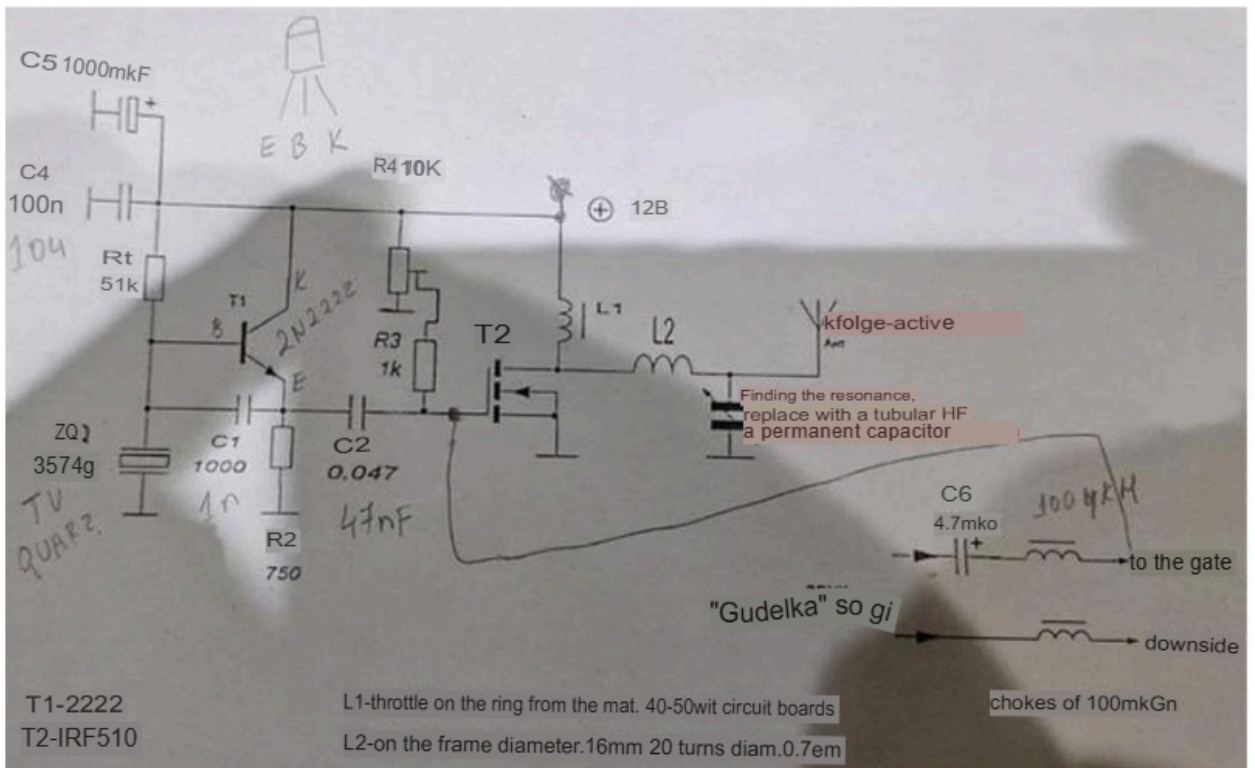

This circuit requires a so-called "buzzer" for 50 Hz. Its circuit is shown in the figure below:

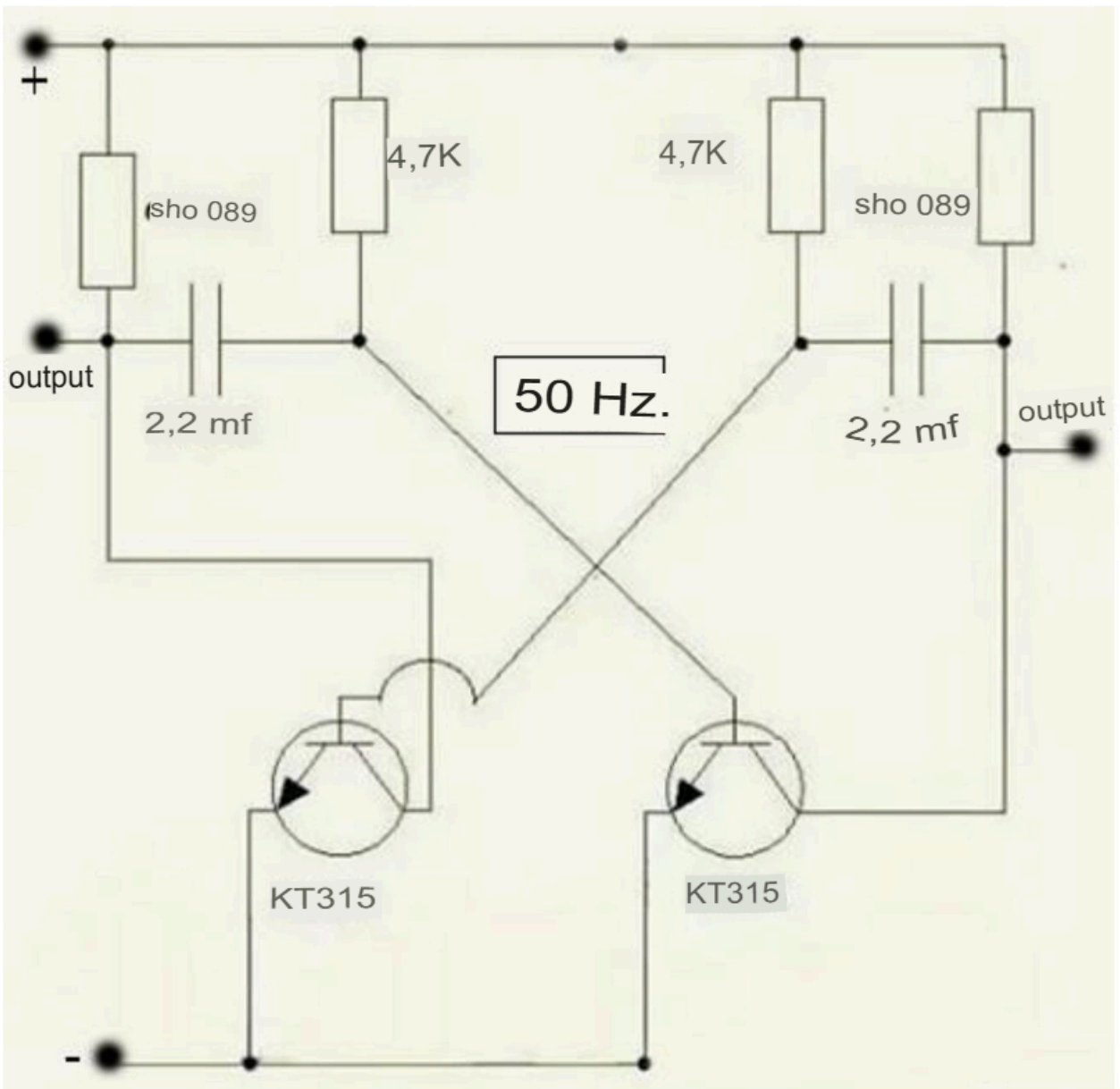

Below are some other varieties of "buzzers":

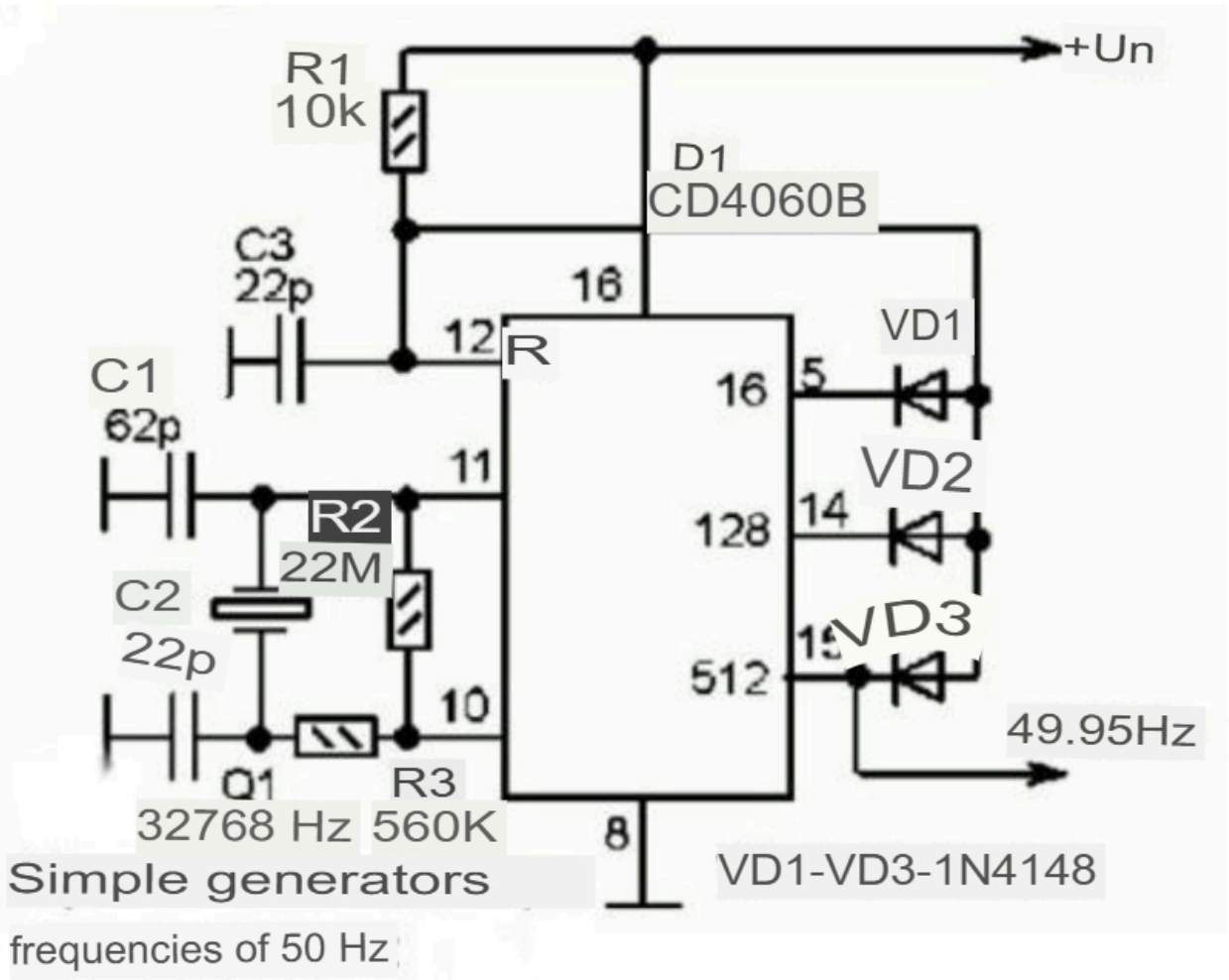

And, - next:

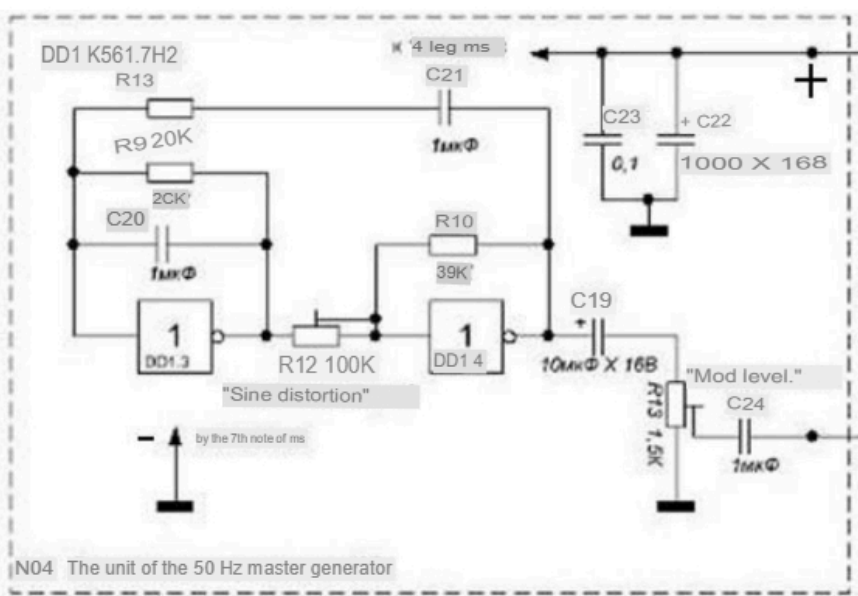

This concludes our review of the active amalgam (foil) we're using !

Now , a description of how to connect the feedback circuit — specifically, the operating system. Below is a detailed drawing/image:

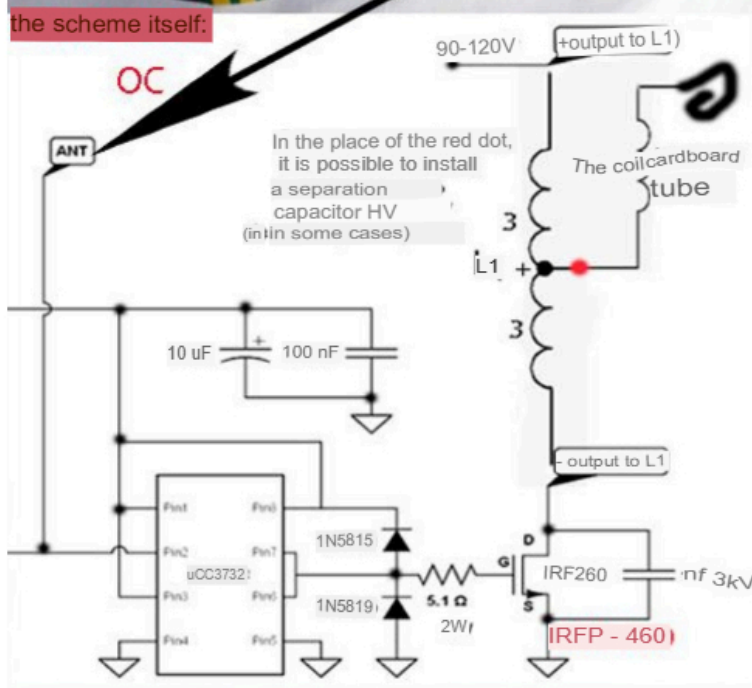
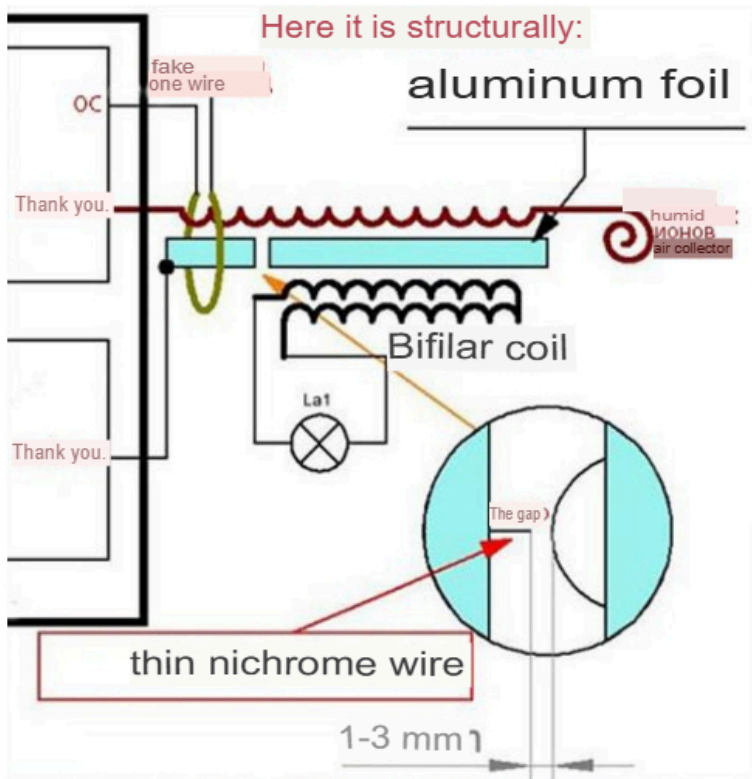

Now further - the MAIN DIAGRAM! of the fuel-free system; it is shown here - below:

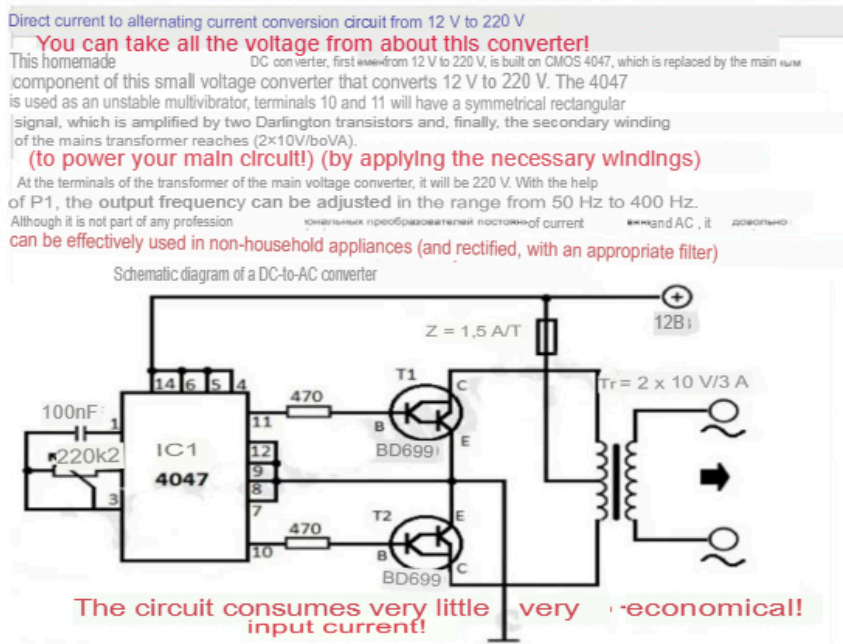

-input 12-24v

+input 12-24v

(Cx. almost like in a black and white movie)
(with a very small change)



In the place of the red dot, it is possible to install a separation capacitor HV (in some cases)

the coil) cardboard tube

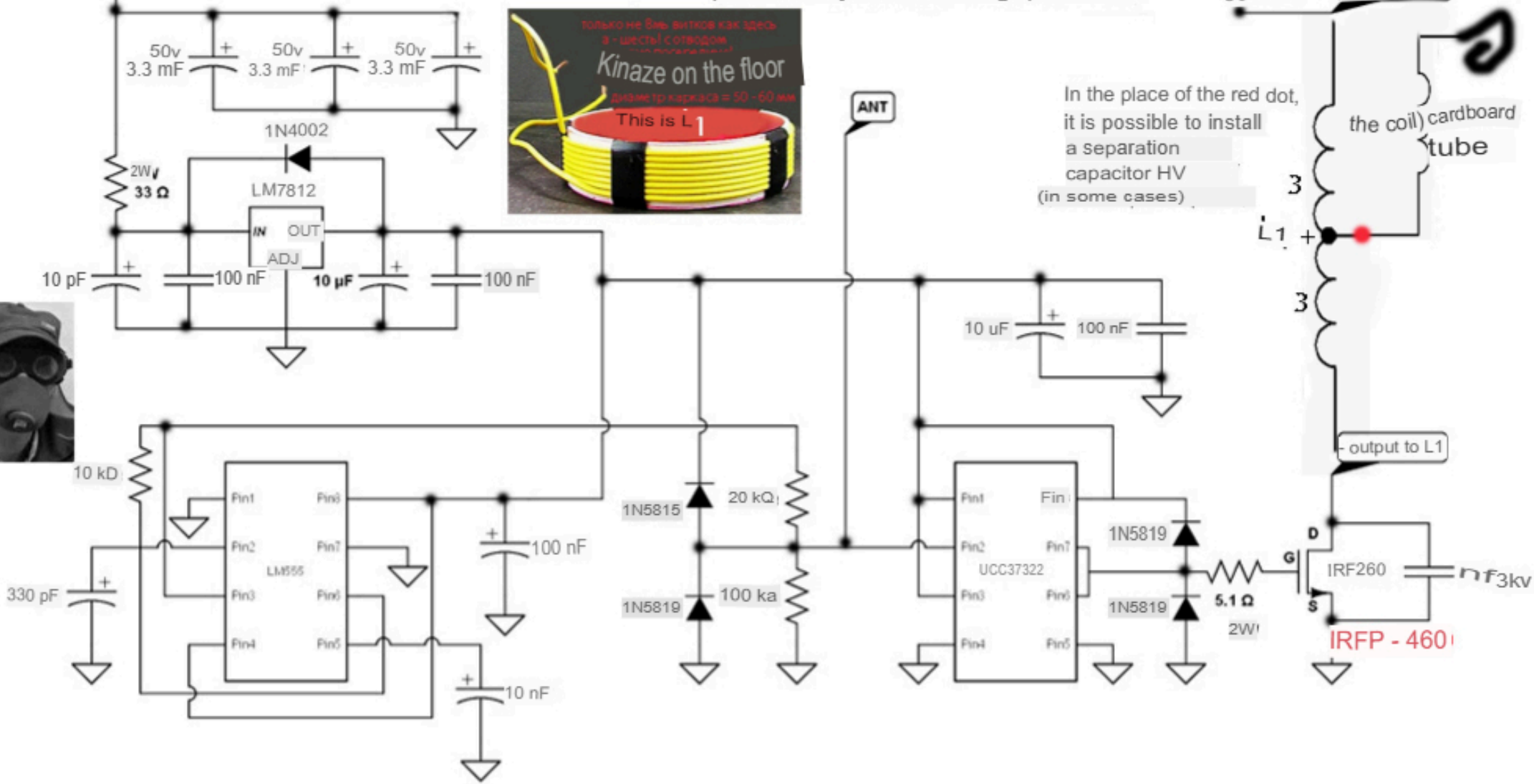

IRFP - 460!